

# DESIGN OF NETWORK TOOLS FOR DETECTING EGG CONDITIONS



Name : Sitta Rizqi Ramdlanianto

Nim : 14150049

class : 14 TEL 02

## BACKGROUND

- The condition of people with visual impairments is very limited, so they need other people to be able to help them walk, know the type of object, know the condition of the egg whether it is still suitable for use or not, and so on. To be able to find out the condition of eggs, blind people cannot use the general method of telescoping because they do not have eyes that can see. Because of that, the writer wants to design a Final Project that can help people with visual impairments to know the condition of the egg whether it is still suitable for use or not with the title "DESIGN OF NETWORK TOOLS FOR DETECTING EGG CONDITIONS"
- **Research purposes**
  1. To develop the final task that has been made about egg detection devices to be a visual aid tool to detect the condition of eggs using 2 sensors to be more sure there is no error during the detection process and the output is not displayed in the form of an LCD display but the output uses voice so that people with visual impairments can be heard.
  2. To design a tool that is useful for people with visual impairments so they can do work that usually has to be assisted by others because not necessarily other people are always there for those with visual impairments.

## Scope of problem

1. Using a simple container to place the eggs.
2. Using an Arduino microcontroller for the system controller.
3. Using electric power supply.
4. Using the infrared sensor and light sensor to detect conditions egg.
5. Use the start button to start the detection process.
6. Using the sound player for information on egg conditions.

## Block Diagram Design



# Overall Series

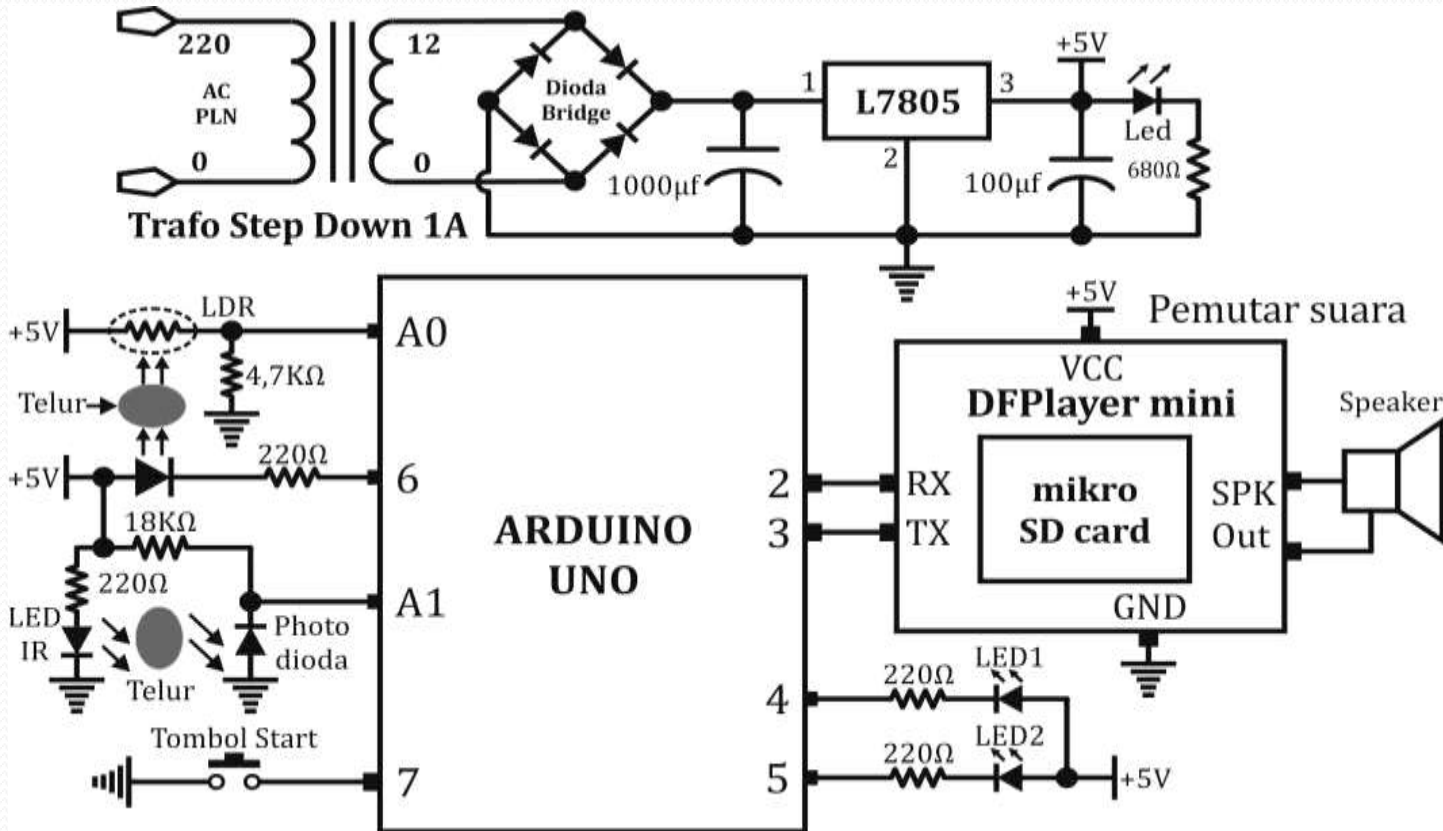

# FLOWCHAT

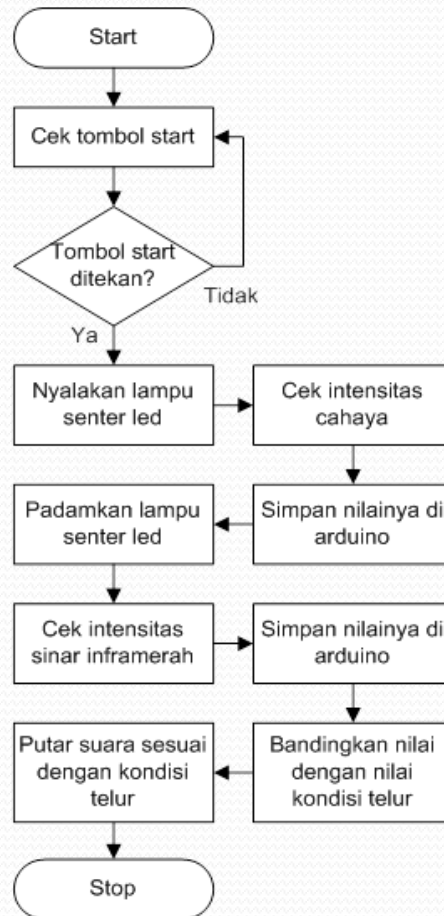

## Tools preparation

- To be able to do testing, there are several preparations that must be prepared first.
- Prepare 2 pieces of placemat for eggs, a place for eggshells is used paralon pipes, in the paralon pipe is placed a very bright LED light to illuminate the eggs from below. Place the light sensor on the back of the egg so that when the led light illuminates the egg, the light sensor can detect the translucent intensity of light from the egg. Then place the infrared sensor on the right and left of the egg, so that the infrared sensor can detect the infrared light intensity that penetrates from the egg.
- After that all systems are ready to be tested in order to find out whether the system can work properly.



## Testing of light sensors

- Light sensor testing is done to find out whether the light sensor placed on the back of the egg can detect the condition of the egg well or not. The test is done by placing the egg in the place of laying the egg with a base of paralon pipe that already has lights in it to illuminate the egg. The first test is done by placing a good egg on the left and right egg tray. Turn on the super bright led lights to illuminate the egg so that light can penetrate the egg and the intensity of the light can be detected by the light sensor. Measure the voltage generated from the light sensor, then record the results in the table. Turn off the super bright led lights, replace the eggs with eggs that are still pretty good, turn the lights back on to illuminate the eggs. Measure the voltage generated from the light sensor, then record the results in the table. Turn off the led lights, then replace the eggs with eggs that are not good, turn the lights back on to illuminate the eggs. Measure the voltage generated from the light sensor, then record the results in the table
- Turn off the led lights, then replace the eggs with broken eggs. In this test, the eggs on the bottom are attached with black insulation so that they are broken eggs. Turn on the led light to illuminate the egg, then measure the voltage generated by the light sensor, then record the results in the table.

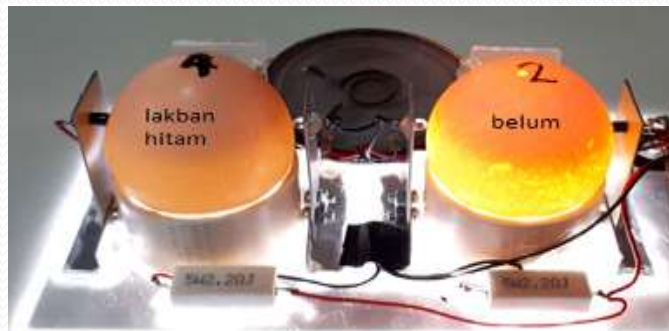



## Sound information testing

- Sound information testing is done to find out whether the sound information produced is in accordance with the condition of the egg. Because using 2 pieces of egg tray and each egg tray is tested with 4 egg conditions, it means that there are 16 variations of sound information produced when testing eggs.

Percobaan ke	Kondisi telur kiri	Kondisi telur kanan	Informasi suara
1	Bagus	Bagus	Kondisi telur kiri dan kanan bagus
2	Bagus	Lumayan	Kondisi telur kiri bagus dan kanan lumayan
3	Bagus	Kurang	Kondisi telur kiri bagus dan kanan kurang
4	Bagus	Rusak	Kondisi telur kiri bagus dan kanan rusak
5	Lumayan	Bagus	Kondisi telur kiri lumayan dan kanan bagus
6	Lumayan	Lumayan	Kondisi telur kiri dan kanan lumayan
7	Lumayan	Kurang	Kondisi telur kiri lumayan dan kanan kurang
8	Lumayan	Rusak	Kondisi telur kiri lumayan dan kanan rusak
9	Kurang	Bagus	Kondisi telur kiri kurang dan kanan bagus
10	Kurang	Lumayan	Kondisi telur kiri kurang dan kanan lumayan
11	Kurang	Kurang	Kondisi telur kiri dan kanan kurang
12	Kurang	Rusak	Kondisi telur kiri kurang dan kanan rusak
13	Rusak	Bagus	Kondisi telur kiri rusak dan kanan bagus
14	Rusak	Lumayan	Kondisi telur kiri rusak dan kanan lumayan
15	Rusak	Kurang	Kondisi telur kiri rusak dan kanan kurang
16	Rusak	Rusak	Kondisi telur kiri dan kanan rusak

## conclusion

From the above description can be drawn some conclusions as follows:

1. In order for the system to detect the condition of the egg properly, the egg must be placed on top of the paralon pipe where there is already a super bright led light to flash the egg, then a light sensor is placed on the back side of the egg to detect the light passed by the egg and infrared sensor placed on the right and left side.
2. The infrared sensor can determine the condition of the egg by detecting the intensity of infrared light passed by the egg and the light sensor can determine the condition of the egg by detecting the intensity of light from super bright led lights passing through the egg.
3. Information that gives information about the condition of the egg is an MP3 player module that already contains a micro SD that has been filled with a sound recording file, then plays the song that is heard using the speaker.
4. The sound information is rotated according to the detected egg condition so that the hearing can determine the condition of the egg.

## Suggestion

1. To be able to be applied can actually use the egg cover casing so that the egg detection process is more perfect but the casing that can be opened is easily closed by the blind.



Thank's you 😊