

**AUTOMATED GUIDED VEHICLE DESIGN USING
INDUCTIVE LINE FOLLOWING METHOD
ON AS/RS: AS A SIMULATION IN SKILL DEVELOPMENT CENTER OF
AUTOMATION INDUSTRIAL ENGINEERING FACULTY TELKOM
UNIVERSITY**

Prasetia Pramudita Yuliarso¹, Haris Rachmat, S.T., M.T.², DRS.Tatang Mulyana, M.T., PhD.³

^{1,2,3}Prodi S1 Teknik Industri, Fakultas Rekayasa Industri, Universitas Telkom

¹prasetiapramudita@gmail.com, ²haris.bdg23@gmail.com, ³tatang21april@gmail.com

Abstract

This paper study about the simulation of how AGV work using Robotino[®]. The simulation is needed as a material for studying about AGV. The use of Robotino[®] as an AGV because the characteristics is similar with AGV. It will pick up material and transport it from one workstation to another workstation using inductive line as a guidance. After that it arrive in another workstation, it will put down the material on the workstation. To be able to move safely on the inductive line, it can use speed of 200 mm/s.

Keywords: AGV, inductive line

I. Introduction

An automated guided vehicle system (AGV) is a battery-powered material handling that uses independently operated, self-propelled vehicles guided along define pathways. AGV usually used to move pallet loads in manufacture or warehouse and moving work-in-process along variable routes in low and medium production. The advantages are battery-powered vehicles, flexible routing, and nonobstructive pathways. The disadvantages of AGV is high cost. In a complex manufacturing process, the use of industrial trucks and AGV are preferred because both of them are highly flexible. The difference is industrial trucks are run manually by human and AGVs are run automatically. The difference between those are forklift truck is still controlled by human while the AGV is not controlled by human. Work performed by a fork lift truck is susceptible to fatigue and stress due to position or work environment that uncomfortable. Sometimes the uncontrolled maneuver of fork lift truck will cause damage to the product. This accident can happen because of the human error. One of factor that influence human error is physiological factor. Therefore, for security issue AGV has a great advantage compared with a fork lift truck, because AGV is unmanned material handling. Study about AGVs in manufacture is quite important in manufacturing system. Because, in this modern era, the manufacturing system will be more complicated. Manufactures are required to meet the high demand. To be able to learn about the workings of AGV, then simulation is needed.

Inspira automation is one of the skill development center in Telkom University. This skill development center serve the students to be understand all about the automation things in the manufacturers, such as: automation system of material handling; automatic tools machine; feedback control system; computerized system for data collection, planning and decision-making to support manufacturing activity. To learn the automation system, certainly, need a tool. This skill development center already have a learning tools from Festo-Didactic, PLC OMRON, PLC Siemens, etc. The learning tools from Festo that already owned are: pneumatic, electro-pneumatic, Robotino[®]. But this skill development center still do not have a learning module for learning the automated guided vehicle.

Based on the above issues, in this research will discuss about the simulation of AGV using Robotino[®] in Inspira Automation Telkom University. The simulation is conducted as a material for studying about AGV. The use of Robotino[®] as an AGV because the characteristics of Robotino[®] is similar as an AGV. This robot will be programmed similar with how AGV work. The characteristics of this robot will be designed to carry the product based on its color and put it in a place that have been determined. This robot will follow the pathway when carrying the product.

II Literature Study

Automation can be defined as the technology by which a process or a procedure is performed without human assistance. The work of human may be present as observers or even participants, but the process of automation itself operates under its own self-direction. Automation is implemented by means of a control system that executes a program of instructions. To automate a process, power is required to operate the control system and to drive the process itself [2]. There are three basic elements of automation system [2]. Based on the basic element of automation, in this case there are three basic element of Robotino[®]. It can be seen in Figure II.1.

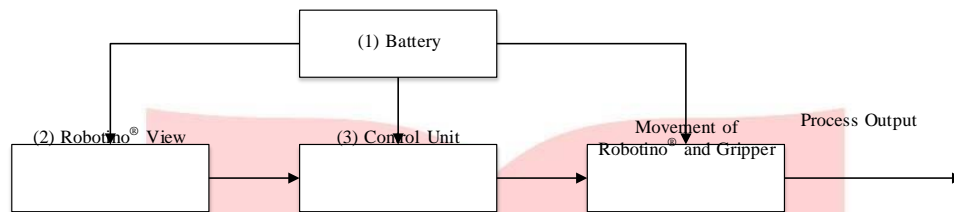

Figure II.2 Element of Robotino[®]

From Figure II.2, there are three basic element of Robotino[®], such as:

1. Battery: a basic element which used to operate multiple processes in driving and controlling all the components in the Robotino[®] system. In Robotino[®], battery is used as the main power.
2. Robotino[®] View: an element that is used to programmed the work process of Robotino[®].
3. Control Unit: an element which is the brain of the Robotino[®] system and serves to regulate the overall work process.

Robotino[®] is a commercially available mobile robot from Festo Didactic. It is used for both education and research, including competitions like RoboCup. Robotino[®] is equipped with nine infrared distance measuring sensors. This sensor is used to determine the distance object from Robotino[®]. This sensors are mounted on the chassis at an angel 40° to one another. Each sensors can be queried individually via the I/O circuit board. With this sensor, Robotino[®] can avoid any obstacle around it. Sensor connection is especially simple including just one analogue output signal and supply power. The sensor's evaluating electronics determine distance and read it out as an analogue signal [12]. It can be seen in Figure II.3.

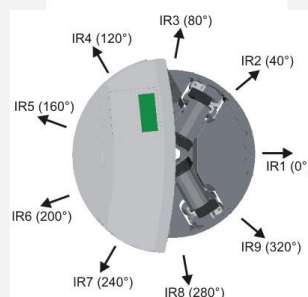

Figure II.3 Distance sensor of Robotino[®]

In this case, there are nine hardwares use to make the Robotino[®] acting as an AGV such as: the default hardware of Robotino[®], PC or laptop to make the program, gripper system, inductive sensor, webcam logitech c525, aluminium tape that is use as a guidance to move, workstation that built from acrylic, slider that built from acrylic, and the material it self. There are three material that is used in this case based on the color, red material, blue material, and yellow material. Those material are built from wood.

The system requires software that will be used to control the Robotino[®] in the process of pick up and put down material. Two softwares that will be needed to run the AGV are as follows: first is Operating System Windows 7, this software is used to operate all of the systems in the Notebook. And the second is Robotino[®] View, this software is used to communicate the PC/notebook with Robotino[®] as an automated guided vehicle. The program for controlling Robotino[®] can be create here.

In a manufacturing, automation technology will be useful if implemented. There are nine reasons why automation is useful if the manufacturer implementing it [2]. Based on the nine reason why automation is useful if the manufacturer implementing it, in this case just discuss about to reduce labor cost.

III. Scenario Process

Scenario process is the flow of the process that will be perform by the AGV. This scenario process depends on the type of AGV application that will be made and the ability of the processes conducted by the AGV. This scenario process will affect the design of the program that will be made.

To make the scenario process that has been made can run correctly, arena is needed. Arena is the place for the simulation of Robotino® as an AGV. The role of Robotino® as an AGV is to transport the material into the right place. The material will be moved from the sorting workstation to the designated place. To move from one workstation to another workstation, Robotino® will move using an inductive line as a guidance. Arena will be designed to be able to meet the criteria of scenario that have been made. The arena can be seen in Figure III.1.

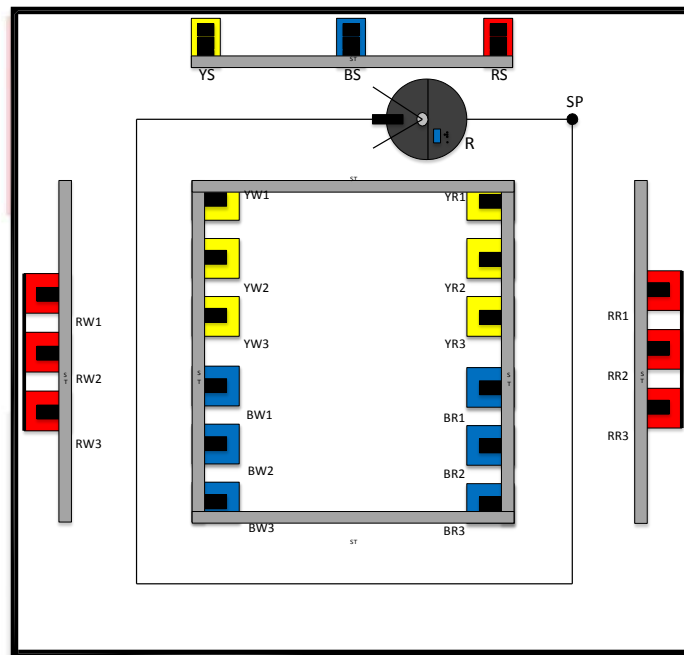

Figure III.1 Arena

Figure III.1 is explain about the desire arena that will be build. There are 24 components that will be placed in arena, such as SP means Start Point, R means Robotino®, RS mens Red Slider, BS means Blue Slider, YS means Yellow Slider, ST means Sensor Trigger, RW 1/2/3 means Red Workstation 1/2/3, BW 1/2/3 means Blue Workstation 1/2/3, YW 1/2/3 means Yellow Workstation 1/2/3, RR 1/2/3 means Red Rack 1/2/3, BR 1/2/3 means Blue Rack 1/2/3, YR 1/2/3 means Yellow Rack 1/2/3. There are nine processes that will be performed by AGV such as pick up red material from red slider to red workstation 1, pick up red material from red slider to red workstation 2, pick up red material from red slider to red workstation 3, pick up blue material from blue slider to blue workstation 1, pick up blue material from blue slider to blue workstation 2, pick up blue material from blue slider to blue workstation 3, pick up yellow material from yellow slider to yellow workstation 1, pick up yellow material from yellow slider to yellow workstation 2, and pick up yellow material from yellow slider to yellow workstation 3.

One of the example of scenario process is pick up red material from red slider and put down the material to red workstation 1. It can be see in Figure III.2

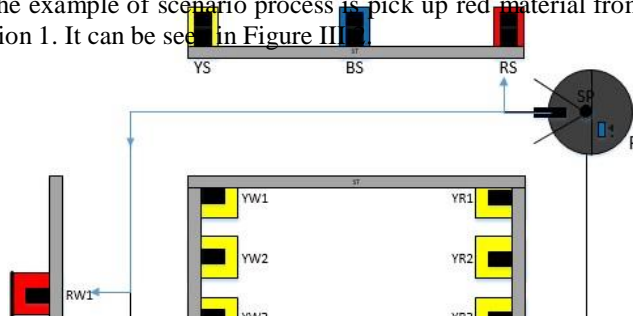

Figure III.2 Pick up red material from red slider to red workstation 1

Figure III.3 Transport red material

From Figure III.2, it can be seen that Robotino[®] is move from start point to red slider. After Robotino[®] arrived in front of the red slider, then it will detect red material and it will pick up the red material. After that Robotino[®] will transport the red material to red workstation 1 through inductive line. Figure III.3 is the real condition when Robotino[®] pick up red material and transport it through inductive line.

The arrival of material that comes from sorting workstation must be random. The first come can be red material or blue material or yellow material. It depends on the material is processed first. Therefore, priority picking is needed to prevent bottleneck after the material has been sorted. So, Robotino[®] will pick up the first coming material. When the material sorted in the sorting workstation, Robotino[®] will move from its starting location to the sorting place. Robotino[®] will move using inductive line following to the sorting place. After the Robotino[®] arrived in the sorting place, then it will check the red slider whether the material has been sort or not. If in the red slider there is no material, then the Robotino[®] will move to the blue slider and check it whether the material has been sort or not. If in blue slider there is no material, then the Robotino[®] will move to the yellow slider and check it whether the material has been sort or not. If in the checking process the Robotino[®] found a material in the sorting place, then Robotino[®] will go forward approaching the sorting place and pick up the material. After that the Robotino[®] will move to the designated place. If the Robotino[®] found a material in the red slider, then Robotino[®] will pick up the material and go to the red workstation. If the Robotino[®] found a material in the blue slider, then Robotino[®] will pick up the material and go to the blue workstation. If the Robotino[®] found a material in the yellow slider, then Robotino[®] will pick up the material and go to the yellow workstation.

IV. Result and Analysis

After Running the simulation, Robotino[®] can act as an AGV. It can move using an inductive as a guidance, detect material, pick up material, and put down material. Here is some example of the program that has been created using Robotino[®] View.

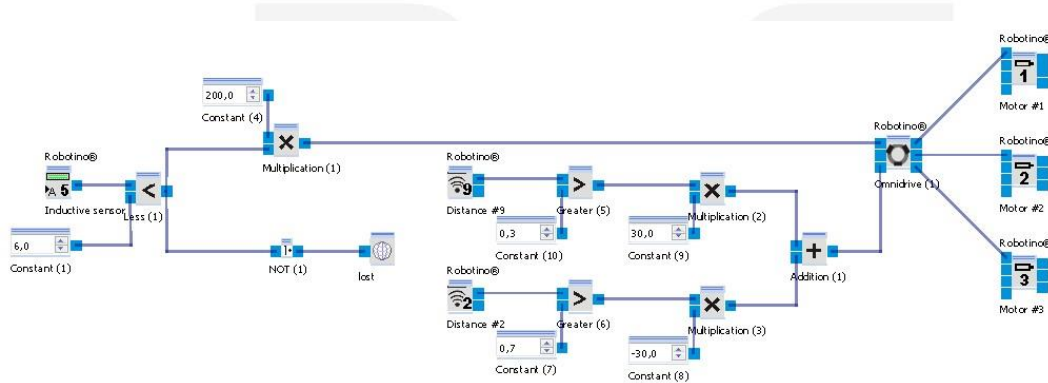

Figure IV.1 Move Forward

From Figure IV.1, it can be seen that if the value from Constant (1) is less than 6 it means that Robotino[®] still can detect the inductive line. if the value is more than 6, it means that Robotino[®] cannot detect the inductive line. If Robotino[®] can detect the inductive line, then it will move with speed 200 mm/s. The use of sensor distance #2 and #9 is to balance the Robotino[®] when moving. Because sometimes Robotino[®] move not straight. To make sure that Robotino[®] still can move on the inductive line, the speed testing is needed. It can be seen in Table IV.1.

Table IV.1 Speed Testing

speed	Initial Condition	Running	
		without sensor 2 and 9	with sensor 2 and 9
100	straight	on the line	on the line
	not straight	out of the line	on the line
200	straight	on the line	on the line
	not straight	out of the line	on the line
300	straight	on the line	on the line
	not straight	out of the line	on the line
400	straight	on the line	on the line
	not straight	out of the line	out of the line
500	straight	on the line	on the line
	not straight	out of the line	out of the line
600	straight	on the line	on the line
	not straight	out of the line	out of the line
700	straight	on the line	on the line

	not straight	out of the line	out of the line
800	straight	on the line	on the line
	not straight	out of the line	out of the line

From Table IV.1, it can be seen that Robotino® still can move on the line with speed below than 300 mm/s either use sensor 2 and 9 or not use sensor 2 and 9. But, with using speed 300 mm/s, sometimes Robotino® still can move out of the line. So, for safety Robotino® can use speed 200 mm/s to move using inductive line as a guidance. For speed more than 300 mm/s, Robotino® always move out of the inductive line.

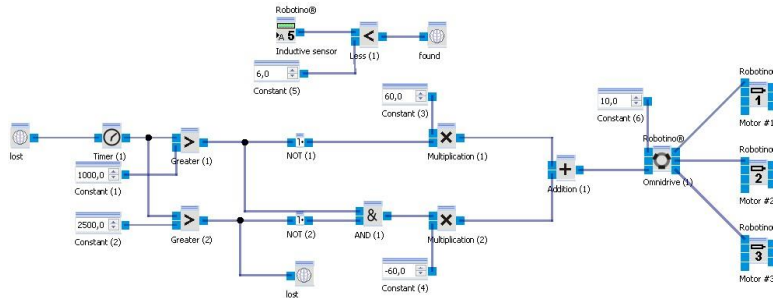

Figure IV.2 Find Line

In Figure V.2, when the range time is between 0 until 999,99 ms, Robotino® will turn counter clockwise with speed 60 mm/s and when the range time is between 1000 until 2499,99 ms, Robotino® will turn clockwise with speed 60 mm/s. If the time is more than 2500 ms, this sub program will looping until it can find the inductive line. The value in Constant (6) means that Robotino® will move forward with speed 10 mm/s during rotate clockwise and counter clockwise. If the value in Constant (6) is bigger, Robotino® will crush into the wall because it is move too fast when it still find the line.

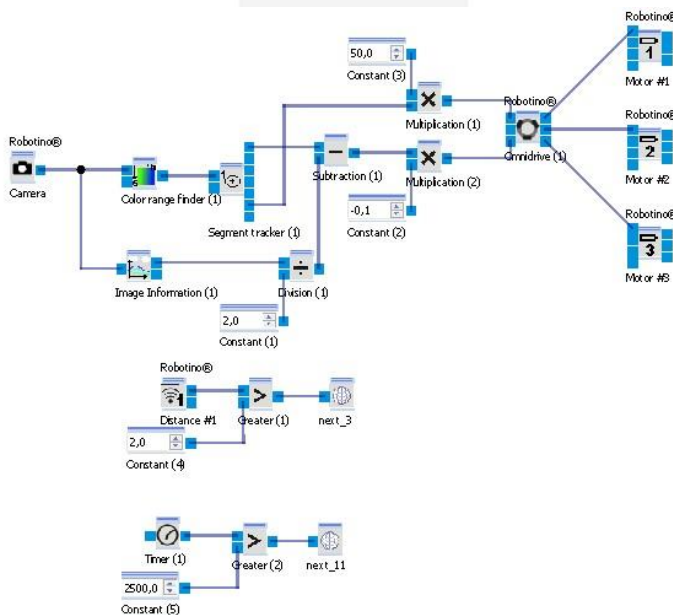

Figure IV.3 Program Detect Red Material

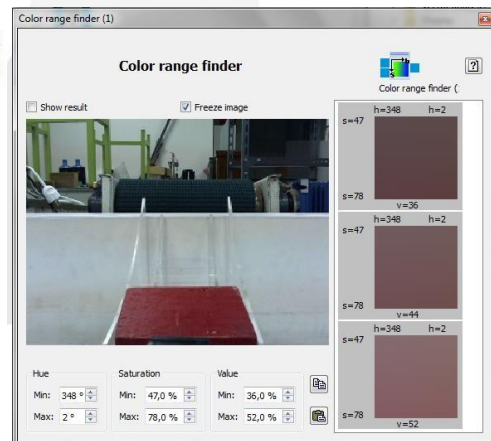

Figure IV.4 Detect Red Material

In Figure IV.3, Robotino® will detect the desire color of material. When the material is found, Robotino® will move forward with speed 50 mm/s. If the Robotino® cannot find the desire material, it will rotate to find it. The Robotino® will rotate in a certain time. If the time is run out, then this sub program will be stop. Figure IV.4 is the real condition of detect red material. To be able to pick up the material based on its color, so it must be decided which color that will be taken. To determine which color that will be taken, can be seen in Figure IV.4. Figure IV.4, is the result of taking the desired color of red material. After capture the image of the material, the value will come out automatically. This program will automatically find the material with range of hue from 348° until 2°, range of saturation is from 47% until 78%, and value from 36% until 52%. If the Robotino® cannot detect the color of material within that range, so it will try to find the red material within those range for 2499,99 ms.

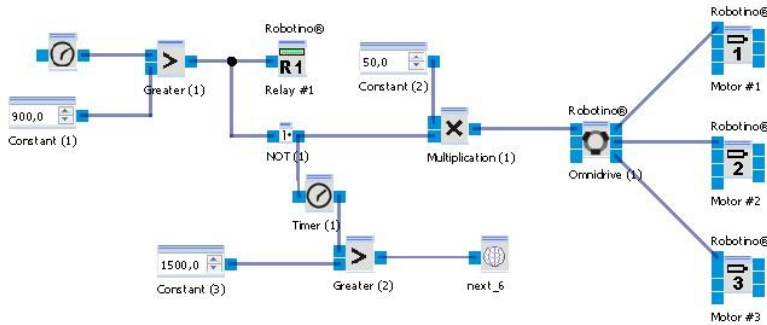

Figure IV.5 Gripper On

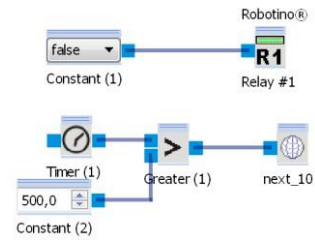

Figure IV.6 Gripper Off

In Figure IV.5, Robotino® will move forward based on the time. To determine how much time needed for Robotino® to stop right in front of the object, very close with the object, it should be done several times of trial and error until the appropriate time obtained. In this case, the appropriate time is 900 ms. Robotino® will move forward from 0 until 899,99 ms. After that Robotino® will stop moving and will activated the Relay #1 which means activated gripper. This sub program will be stop after the time is more than 1500 ms. In Figure IV.6 when Robotino® running this program, the gripper will automatically off. Because the input for Relay #1 is false. After 500 ms, this program will be stop.

There are some deficiencies in this system. Such as the distance of distance sensor, find line, and battery.

1. Distance sensor or infra-red sensor

There are nine infra-red sensors that mounted in Robotino®. The distance of each sensor is 40°. Sometimes Robotino® cannot detect an object because of the position of Robotino®. It can be seen in Table IV.2. From the Table IV.2, it can be seen that eventhough the value of sensor Distance #1 in software Robotino® View is different, the distance is almost same. The value in Robotino® View is obtained from adjust the Robotino® in front of each workstation manually. The distance between each workstation is 11 cm. For the process go to Red WS 1, 2, and 3 Robotino® cannot stop right in front of each workstation it because of the sensor Distance #1 cannot detect the distance appropriately. For the process fo to Blue WS 1, 2, and 3 Robotino® also cannot stop right in front of each workstation appropriately. This condition also same for the process go to Yellow WS 2 and 3 Robotino® cannot detect the distance appropriately. But, for process go to Yellow WS 1, Robotino® can stop right in front of the Yellow WS 1. It is because Yellow WS 1 is the first workstation in this scenario case and the distance between Yellow WS 1 to wall is 145 cm.

2. Find line

When the Robotino® out of the inductive line, it need some times to find the inductive line. So, when the Robotino® often out of the inductive line, it will need more time to finish its process.

3. Battery

The battery used in this case is a bad condition of battery. The use of battery is just for 1,2 hours. But for recharging the battery, it need 1,4 hours.

Analysis of costing is needed to know whether the use of Robotino® can reduce the cost or not. In this case, it will compare the use of 1 Robotino® with 1 labor and 1 Forklift truck with 1 labor based on the electricity. Because of that data and assumption is needed. The purpose of Data and assumption is to provide the real data and assumption for the calculation. It can be seen in Table IV.3.

Table IV.2 Distance of sensor 1

Process	Value in Robotino View	Distance from wall (cm)							
		Trial							
		1	2	3	4	5	6	7	8
Go to Red WS 1	0,06	167	163	163	163	166	166	163	163
Go to Red WS 2	0,1	168	167	164	166	163	163	165	168
Go to Red WS 3	0,14	163	166	167	165	168	162	165	167
Go to Yellow WS 1	0,07	162	167	166	166	166	166	167	165
Go to Yellow WS 2	0,045	168	166	164	162	162	166	166	162
Go to Yellow WS 3	0,075	168	163	163	164	168	168	164	163
Go to Blue WS 1	0,12	164	165	163	167	165	166	167	164
Go to Blue WS 2	0,16	162	164	162	164	164	162	164	168
Go to Blue WS 3	0,24	167	166	164	167	168	162	163	166

Table IV.3 Data and Assumption

Data Financial		
Data	Value	Source/information
Regional minimum wage of Bandung district	Rp 2.001.195,00 / month	Keputusan Gubernur Jawa Barat No. 561/Kep. 1581-Bangsos/2014
Bank Interest Rate	7,50%	http://www.bi.go.id/id/moneter/bi-rate/data/Default.aspx
Evaluation plan	5 Year	2016-2020
Hardware depreciation	5 Year	Straight Line Depreciation
Electricity cost	Rp 1.200 / kWh	http://www.pln.co.id/disjaya/files/2014/12/Tarif-Industri.png
Consumption charger power of Robotino	56 Watt / second	Information from charger
consumption charger power of forklift truck	1440 Watt/ second	http://sentrada.com/nuovaelettra
Recharge battery of robotino	1,4 hours	manually
Recharge battery of forklift truck	8 hours	http://hargaforkliftelectric.blogspot.com/2014/07/cara-merawat-batere-battery-forklift.html
Number of working days per year	308 days	360days or 52 weeks

After obtain all of the data, the next step is calculate the data. There are two data which calculated, first is NPV for using 1 Robotino[®] and 1 labor, and the second is NPV for using 1 Forklift truck and 1 labor. From Figure IV.4, it can be seen that if using 1 Robotino[®] and 1 labor, the NPV cost per year is Rp 2.017.615,-. So, the total NPV from 2015 until 2020 if using 1 Robotino[®] and 1 labor is Rp 10.611.076,-. From Figure IV.5, it can be seen that if using 1 Forklift truck and 1 labor, the NPV cost per year is Rp 5.824.459,-. So, the total NPV from 2015 until 2020 if using 1 Forklift truck and 1 labor is Rp 29.645.294,-. From Table IV.4 and Table IV.5, it can be seen that NPV cumulative cost for using 1 Robotino[®] and 1 labor is less that using 1 forklift truck and 1 labor.

Table IV.4 NPV 1 Robotino[®] and 1 Labor

Year	Period	NPV Cost	NPV Cumulative Cost
2015	0	Rp 523.000	Rp 523.000
2016	1	Rp 2.017.615	Rp 2.540.615
2017	2	Rp 2.017.615	Rp 4.558.230
2018	3	Rp 2.017.615	Rp 6.575.846
2019	4	Rp 2.017.615	Rp 8.593.461
2020	5	Rp 2.017.615	Rp 10.611.076

Table IV.5 NPV 1 Forklift Truck and 1 Labor

Year	Period	NPV Cost	NPV Cumulative Cost
2015	0	Rp 523.000	Rp 523.000
2016	1	Rp 5.824.459	Rp 6.347.459
2017	2	Rp 5.824.459	Rp 12.171.918
2018	3	Rp 5.824.459	Rp 17.996.377
2019	4	Rp 5.824.459	Rp 23.820.836
2020	5	Rp 5.824.459	Rp 29.645.294

IV. Conclusion and Suggestion

Based on the research that has been done, conclude that automated guided vehicle design using line following method on AS/RS as a simulation in skill development center of automation Industrial Engineering Faculty Telkom University has successfully designed.

1. The navigation system for Robotino[®] is using inductive line as a guidance. The use of inductive line is to ensure that Robotino[®] can transport the material in accordance with the predetermined line. Robotino[®] can successfully move from one workstation to another workstation using inductive line as a guidance.
2. To pick up the material by its color, Robotino[®] will move to the slider to detect the material on the slider using webcam. When it can detect the material on the slider based on its color, then it will activated the gripper. After that the material will be gripped by the gripper.
3. To put down the material, sensor Distance 1, 3, and 8 of Robotino[®] will detect the distance of the wall to make sure Robotino[®] can stop right in front of the workstation for each material. After Robotino[®] stop in front of the workstation, then it will rotate facing the workstation. After that Robotino[®] will move forward approaching the workstation. When Robotino[®] is has reach the specified distance, then it will stop and activated the gripper to open. And then the gripper will release the material.
4. To be able to move on the inductive line, Robotino[®] can use speed below than 300 mm/s. Because within that speed, Robotino[®] still can be controlled so it will not move out of the inductive line. Sensor Distance #2 and sensor Distance #9 are used as a safety for Robotino[®] to remain on the inductive line. Sensor Distance #2 will make the Robotino[®] rotate to the right when it can detect an object within a specified

distance, while sensor Distance #9 will make the Robotino[®] rotate to the left when it can detect an object within a specified distance. So it will make the Robotino[®] remain on the inductive line.

5. The priority picking is used because with using Robotino[®] View, Robotino[®] cannot figure out which is material that first arrived. Because of that, Robotino[®] will check in every slider whether there is a material or not. If during the process of detecting material Robotino[®] can detect the material, so it will move forward to pick up the material. And if during the process of detecting material Robotino[®] cannot detect the material, so it will move to the another slider. The process of detecting material is based on its color.

As for suggestion given if this research want to develop further, such as:

1. Update the version of Robotino[®] because in this research the version of Robotino[®] is version 2.0. Some of hardwares and softwares is not compatible with Robotino[®] is version 2.0.
2. If the version of Robotino[®] has been upgraded, can use the latest version of Robotino[®] View to program the Robotino[®].
3. Use another sensor for safety, so eventhough the speed is fast Robotino[®] still can remain on the inductive line.
4. Use another sensor for know the specific place, so Robotino[®] can stop or can detect the object more accurate.
5. To move from one place to another place can use gyroscope sensor. With using this sensor, Robotino[®] can move to another place using an odometry or using coordinate.
6. Can use another scenario to determine how many AGV need in the manufacture.

Reference

- [1] Festo. (2014, December). Retrieved from www.festo-didactic.com.
- [2] Groover, M. P. (2001). *Automation, Production System and Computer Integrated Manufacturing 2nd edition*.
- [3] Groover, M. P. (2010). *Fundamentals of Modern Manufacturing 4th Edition*. Wiley & Sons, Inc.
- [4] IGNOU. (2014, October). <http://www.ignou.ac.in/upload/Unit4-55.pdf>. Retrieved from <http://www.ignou.ac.in>.
- [5] Irawan. (2014, December). <https://irawanah.wordpress.com/2012/10/03/keunggulan-sistim-logistik-internal-berbasis-automatic-guided-vehicle/>. Retrieved from [Irawanah.wordpress.com](https://irawanah.wordpress.com).
- [6] KWC. (2014, June). <http://www.ros.org/news/2010/06/robots-using-ros-robotino.html>. Retrieved from www.ros.org.
- [7] Linden, D., & Reddy, T. B. (2002). *Handbook of Batteries 3rd edition*. McGraw-Hill.
- [8] Meyers. (1993). *Plant Layout and Material Handling*.
- [9] NCHU. (2014, October). <http://wwwme.nchu.edu.tw/~CIM/courses/Flexible%20Manufacturing%20Systems/Microsoft%20Word%20-%20Chapter10F-Automated%20Material%20Handling%20and%20Storage%20Systems.pdf>. Retrieved from <http://www.me.nchu.edu.tw/>.
- [10] Orwell, M. (2014, December). http://www.ehow.com/about_4574467_what-camera.html. Retrieved from www.ehow.com.
- [11] Rouse, M. (2014, December). <http://whatis.techtarget.com/definition/sensor>. Retrieved from <http://whatis.techtarget.com>.
- [12] Weber, R.-C., & Bellenberg, M. (2010, October). *Robotino Manual*. Retrieved from www.festo-didactic.com.